



UAS Operations Manual

Updated -3-16-2023

Table of contents

1. General Procedures.....	(2)
2. Flight Planning/Preparation.....	(2)
3. Weather.....	(2)
4. Site Selection.....	(2-3)
5. Flight Team Briefing.....	(3)
6. Accident Reporting.....	(3)
7. Inspection and Maintenance.....	(3)
8. Pre Flight Checklist.....	(4)
9. Emergency Procedures.....	(5-6)
10. Glossary of Terms.....	(7)

1. General Procedures

- 1.1. US Airworthiness Requirements – PIC responsible for continued Airworthiness
- 1.2. UAS Registration and Markings – Placed on UAS
- 1.3. UAS Control Frequency – In Compliance with FCC or local governing agency
- 1.4. Manufacture Manuals – UAS To Be Operated in Accordance with UAS Operation Manuals
- 1.5. Flight Team Members
 - 1.5.1. Pilot – PIC, Current Part 107
 - 1.5.2. Visual Observer – Knowledge of role
 - 1.5.3. Camera Operator – Able to take over control if pilot incapacitated -Current Part 107
 - 1.5.4. System Engineer/Assistant - Knowledge of frequency and voltage monitoring. Assist in preparation and crowd control.

2. Flight Planning/Preparation

- 2.1. Access feasibility of flight
- 2.2. Assessment of Proposed Operating Site
- 2.3. Pre-Notification – Verify if Any NOTAMS
- 2.4. FAA Coordination with FISDO or governing body
- 2.5. Site Permissions – Obtain from landowners for takeoff/landing
- 2.6. Proximity to Air Traffic Control
- 2.7. Documentation

3. Weather

- 3.1. Wind Speeds - Do not exceed over 30 mph winds or gust spreads of 10mph or more.
- 3.2. Precipitation - Do not fly in rain, if flight encounters rain return to launch as soon as practical. The airframe and motors are water resistant and most likely will not create an emergency however it may affect performance.
- 3.3. Temperature - Temperatures above 95 F (35C) are allowed however flight time and engine performance may be reduced. Limit flight time as much as practical and keep an eye on Motor and ESC temperature. If the motor reaches over 250 degrees at landing pause flight and allow Motors and ESC's to cool. Motor temperatures over 180C can damage the motor.

Temperature- Temperatures below 35F 2C are allowed, however performance can be affected. The biggest concern for low temperatures are poor battery

performance, and plastic parts becoming more brittle. Keep batteries warm at or around 60F 15C. Inspect key structural plastic components for cracks or chips.

- 3.4. Density Altitude - As Density altitude increases, aircraft performance decreases, please mind payload and amperage for flights above 5000 feet density altitude. Expect lower flight times and higher current draw.
- 3.5. 500 below ceiling, 2,000 horizontal from cloud, 3 miles visibility

4. **Site Selection**

- 4.1. Sterile Area and Airspace Control
- 4.2. Only flight members in controlled area
- 4.3. Separation Distances - Determined by PIC
- 4.4. Ground Inspections – Wires, Guidelines, non-essential personnel
- 4.5. Cordoned off from public – tape, cones, signs
- 4.6. 500 feet from non-participating persons
- 4.7. Consent from those closer than 500 feet
- 4.8. Extra security personnel as needed
- 4.9. See-and-Avoid / Visual Line of Sight - Mandatory
- 4.10. Notification of Operations - Local Sheriff, police, fire, gov't officials – permissions/permits as required

5. **Flight Team Briefing**

- 5.1. Take-Off and Landing Zones – Determined before flight
- 5.2. Normal Flight Operations –
 - 5.2.1. Max Speed -
 - 5.2.2. Altitude -
 - 5.2.3. Reserve Power – 5 Minutes or follow manufacturers guidelines - See Appendix B
- 5.3. Flight Team Member Positioning
- 5.4. Roles and responsibility of team
- 5.5. Communication Plan
 - 5.5.1. Two-way radio and/or cell phone
- 5.6. Contingency Plan
 - 5.6.1. Abort Parameters
 - 5.6.2. Threats to Mission
 - 5.6.3. Recovery
- 5.7. Emergency Procedures
 - 5.7.1. All other aircraft have right of way and all flights are to remain within line of sight of the UAS pilot and or Visual Observer.
 - 5.7.2. Inform Air Traffic Control if an Emergency
 - 5.7.3. Seek Medical Attention if Required

6. Accident Reporting

- 6.1. FAA Reporting – Report within 24 hours or abide by local governing law
- 6.2. NTSB Reporting - Or local governing body
- 6.3. Local Regulations

7. Inspection and Maintenance Records –

- 7.1. Electronic Record Keeping – OK, if stored on appropriate app/software
- 7.2. Develop an organization level standard operating procedure, specific for your intended use of the aircraft.
- 7.3. Please log: flight location, duration, mission type, takeoffs/landings, battery changes, Day/night, BVLOS, abnormalities.

8. Pre Flight Checklist: (General)

- 8.1. Visual Condition Inspection of the UAS components;
- 8.2. Airframe Structure (Including undercarriage), all flight control surfaces, and linkages;
- 8.3. Registration markings, for proper display and legibility;
- 8.4. Moveable control surfaces(s), including attachment points;
- 8.5. Servo motors, including attachment points;
- 8.6. Propulsion system, including power plant(s), rotor(s), ducted fan(s), etc.;
- 8.7. Verify all systems (e.g., aircraft and control unit) have an adequate energy supply for the intended operation and are functioning properly;
- 8.8. Avionics, including control link transceiver, communication/navigation equipment, and antennas;
- 8.9. Calibrate UAS as required per UAS manual;
- 8.10. Control link transceiver, communication/navigation data link transceiver, and antennas;
- 8.11. Display panel, if used, is functioning properly
- 8.12. Check ground support equipment, including take off and landing systems, for proper operation;
- 8.13. Check that control link correct functionality is established between the aircraft and control station
- 8.14. Check for correct movement of the control surfaces using the control station;
- 8.15. Check onboard navigation and data links;
- 8.16. Check flight termination system and emergency equipment if installed;
- 8.17. Check batteries levels for aircraft and control station;
- 8.18. Check batteries are secure and will not move during flight or turbulence.
- 8.19. Check that any equipment and payloads are securely attached;
- 8.20. Verify communications with UAS and that UAS has acquired GPS location for at least 4 satellites;
- 8.21. Start the UAS propellers to inspect for any imbalance or irregular operation

- 8.22. Verify all controller operation for heading and altitude, including; IMU, gyros, compass and GPS;
- 8.23. If required by flightpath walkthrough, verify any noted obstructions that may interfere with the UAS;
- 8.24. Use PIC discretion to avoid potential RF interference;
- 8.25. Ensure to abide any other supplemental operational guidelines for both aircraft, payloads and ground equipment.

9. Aircraft to Computer Connection:

- 9.1. First time use of BOT may require computer configuration to connect, once this has been established the computer and aircraft will maintain these settings unless altered. To establish drone and computer communication via USB, If this process doesn't work then Go in this order, Read through first before doing,
 - 9.2. -Connect USB cable to drone
 - 9.3. -Turn on controller (if needed, you can power aircraft only for this if desired)
 - 9.4. -Turn on aircraft
 - 9.5. -Let aircraft boot up
 - 9.6. -If engines are making an arming tone, push engine safety switch to temporarily arm the motors (aircraft is safe as you still have to arm autopilot to start engines), motors go through a tone sequence they go silent, Push motor arm safety switch to disarm motors. (Motor arm safety switch flashes red when disarmed and is solid red when armed)
 - 9.7. -Connect USB cable to computer
 - 9.8. -Open device manager and find the com port your drone is using. (To do this plug in and unplug the usb while you are looking at Com Ports on the Device Manager tree, when the USB is plugged you should see this on the Com Port tree and it will give you a number associated with that Com Port. This will be the com port you select in Mission Planner, this is only done once to verify after that you can use Mission Planner to detect the com port in the same fashion as before on the device manager.)
 - 9.9. -Open Mission Planner
 - 9.10. -In the upper right corner of Mission Planner are drop down boxes, one labeled Com Port another Baud rate. When using USB we use a Baud of 115200, when using Data link its 57600.
 - 9.11. -With Drone USB connected Mission Planner open, select the com port number and the baud rate

- 9.12. -Click Connect, you should see the screen flicker and a box opens up with a green bar to show connection and parameter download, once Parameters are loaded the screen will come alive and you are connected.
- 9.13. -If it stalls out and doesn't connect we need to trouble shoot Device driver, com port, speed and sometimes a bad USB cable. You can also try connecting directly to the side of the autopilot, do that if external USB port may be suspect. If Autopilot works and external USB does not we may have bad wiring or autopilot connection/configuration.
- 9.14.

10. **Emergency Procedures:**

10.1. **Fly Aways**

- 10.1.1. Maintain visual contact;
- 10.1.2. Verify remote controller is powered on;
- 10.1.3. Toggle flight modes to gain control;
- 10.1.4. If unable to establish link, continue to maintain visual on the UAS and update pertinent authorities.

10.2. **Loss of GPS**

- 10.2.1. If GPS signal is lost in flight, return to home and intelligent flight modes will be unavailable;
- 10.2.2. If UAS is flying erratically but still linked, switch modes from GPS to a manual flight mode;
- 10.2.3. Continue flight without GPS, Pilot the UAS to a safe LZ
- 10.2.4. Perform a manual landing and shut down.

10.3. **Low Battery**

- 10.3.1. Maintain visual contact with the UAS
- 10.3.2. Immediately return UAS to you for landing
- 10.3.3. If unable to return home, use onboard cameras to spot the closest suitable landing zone.
- 10.3.4. If unable to land before loss of power, PIC has discretion whether to deploy emergency parachute or not based on environmental and safety factors.

10.4. **Battery Fire**

- 10.4.1. Execute flight termination procedures

- 10.4.2. If unable to land before loss of power, PIC has discretion whether to deploy emergency parachute or not based on environmental and safety factors.
- 10.4.3. Use of Haltron and CO2 Fire extinguishers preferred.
- 10.4.4. If possible, allow a safe amount of time (approximately 30 min) to pass before attempting to salvage or clean up any wreckage.

10.5. Lost Link

- 10.5.1. Maintain visual contact with UAS
- 10.5.2. Verify remote controller is powered on;
- 10.5.3. Move towards UAS if possible;
- 10.5.4. If unable to re-establish link: continue to maintain visual with UAS, update ATC or pertinent authority with position of UAS

10.6. Collision

- 10.6.1. Immediately release all control sticks;
- 10.6.2. If UAS regains control, maneuver the UAS away from the object and return the UAS as safely as possible;
- 10.6.3. If UAS does not regain stability, it is the PIC's discretion as to whether or not to deploy emergency parachute and/or initiate manual motor shut down to reduce the impact speed.

10.7. Loss of Control Surface or Power Plant

- 10.7.1. Make any and all attempts to steer drone to nearest emergency LZ;
- 10.7.2. PIC discretion to deploy parachute or utilize emergency equipment;
- 10.7.3. If UAS does not regain stability, it is the PIC's discretion as to whether or not to deploy emergency parachute and/or initiate manual motor shut down to reduce the impact speed.

*All parachute systems will be operated in accordance with the manufacturers guidelines.

11. Charging/Battery service

11.1. Charger Hyperion EOS 720i Duo 500W charger:

Glossary of Terms

- AGL - Above Ground Level.
- ATC - Air Traffic Control
- COA - Certificate of Authorization
- Ceiling - Broken or overcast clouds
- Density Altitude - Air density given as a height above mean sea level.
- FAA - Federal Aviation Authority
- FCC - Federal Communications Commission
- FISDO - Flight Standards District Offices
- GCS - Ground Control Station.
- GPS - Global Positioning System
- IMU - Inertial Measurement Unit
- LZ - Landing Zone
- METAR - Aviation Weather Report.
- NOTAM - Notice to Airmen. A notice released by an aviation authority to alert PICs of potential hazards on a flight route, or at a location that could affect the safety of the flight.
- NTSB - National Transportation Safety Board
- Part 107 - Current FAA regulation governing commercial UAS operations in USA.
- PIC - Pilot In Command. Responsible for all flight operations.
- RF - Radio Frequency
- UAS - Unmanned Aerial System.
- Visual Observer (VO) - Responsible for monitoring the operational area to ensure that there are no hazards that may endanger the flight or people not part of the UAS flight operation team.
- VLOS - Visual line of sight.

Appendix A

Requirement for Visual Observer - VOs will be briefed by PIC prior to all flights. The VOs primary responsibility will be to maintain Visual Line of Site with the UAS and assist the PIC.

Aircraft:

Model	Brand	Model #	Approx. Manufacture Date	S/N
BOT	ATI			

Payload & Communications

Payload control and monitoring links depend on exact payload used; which includes a secondary 2.4 GHz transmitter/receiver for motion control and real-time video transmission feed.

Operating Frequencies - 2.400-2.483 GHz; 5.725-5.825GHz; 900MHz

Request of NOTAM

A distant (D) NOTAM must be issued when unmanned aircraft operations are being conducted outside of the blanket 200-foot COA. This requirement should be accomplished:

(a) XXXX or NOTAM issuing authority,
or

(b) By contacting the NOTAM Service Station at XXXXXX not more than 72 hours in advance, but not less than 24 hours prior to the operation, unless otherwise authorized as a special provision. The issuing agency will require the Name and address of the pilot filling the NOTAM request, Location, altitude, operating area, Times and purpose.

Submission of Plan of Activities

At least three (3) days before

Name and phone number of the operator for the UAS

Name and phone number of the person responsible for the on-scene operation of the UAS;

Make, model, and serial number or N-number of the UAS to be used;

Name and certificate number of the UAS PICs involved

A statement that the operator has obtained permission from property owners and/or local officials to conduct flights made available to the inspector upon request;

A description of the activity, including maps or diagrams of any area, city, town, county, and/or state over which will be conducted

and the altitudes essential to accomplish the operation.

Additional Operational Guidelines

Standard BOT Aircraft Preflight Power up procedure:

1. Remove aircraft from the case and unfold arms, make sure the C-clip that holds the arm is not cracked or broken.
2. Extend landing gear legs and ensure locking mechanisms are secure.
3. Install props, make sure not to force threading of the propeller, if the propeller does not want to thread make sure you're installing the correct propeller per rotation of the motor. Props should easily thread and tighten, do not over tighten the propeller.
4. Ensure dome and GPS antenna are correctly attached and orientated and that dome will not depart aircraft during flight.
5. Install and secure payload.
6. Install and secure Batteries, make sure they are secure and will not get loose after turbulence or vibration. Make sure battery wires and connectors will not interfere with propeller, min distance of object to propeller is .5 inch.
7. Ensure aircraft battery and controller/GCS batteries are charged for flight.
8. Attach antennas if removed.
9. Power up ground station, connect data link cables to controller or computer
10. Power up controller, ensure switches on controller are in the default startup position.
11. Position aircraft in a good location for takeoff and landing, make sure no dirt rocks or debris will get kicked up during takeoff and landing.
12. Power up one aircraft battery and look at lights and listen to tones for proper boot up.
13. Once boot up complete plug in the second battery, make sure battery connections are secure and not easily unplugged or too difficult to plug in.
14. Press Motor Arm Safety Switch if intending to run motors, if not arm then disarm so ESC don't emit a constant tone.
15. Verify controller connection to aircraft, commence connection of aircraft to GCS laptop or tablet. Verify correct information is present on GCS.

16. Load mission on aircraft if created, verify on Flight Data page mission is present and correct.
17. Turn on video equipment and verify video and or payload control is correct. Set any camera calibration or reflectance panel is performed. Verify enough memory for the mission is present on SD card of payload.
18. Verify the area is clear for launch, verbally announce takeoff or landing loudly so people can hear.
19. Arm autopilot using controllers and prepare to fly aircraft, keep those fingers on the control sticks until stability is verified. Select flight mode and commence flight.

After landing recovery:

1. Make sure the landing area is clear and announce landing.
2. Fly aircraft manually or in an auto land flight mode to a position directly over the intended landing area one aircraft diameter above the landing spot. Once stable and no lateral movement is noticed, the final touch down decent.
3. Once on the ground bring the throttle to lower most mid stick on the throttle stick and wait for the engines to go to idle.
4. Once engines are at idle you can disarm moving the stick to the bottom left or simply keep the throttle center and all the way down and engines will disarm after 15-30 sec. (if by lowering throttle the engines do not go to idle do not use the throttle stick to disarm as this could cause the aircraft to tip over, the aircraft will idle the engines if it has verified it has landed on the ground. Keep throttle low and center and wait until it disarms itself)
5. Once propellers have stopped, approach the aircraft and either power off using battery connectors or disarm the motors.
6. If changing payload please power off as most payloads cannot be installed or removed with power applied to aircraft.

Appendix B:

ICAO

Instructions for Continued Airworthiness

Airframe: Hexacopter tractor motor type. Main material types are carbon fiber, nylon, ABS, Aluminum. Most all these materials are on condition inspection. Most pre and post flight inspections will cover most of the airframe and its parts current condition. If an aircraft has suffered any impact from flying or handling please inspect all parts as below.

It is advisable that a more thorough inspection of airframe components be performed every 3 months or 30 battery cycles whichever comes first.

The frequency of inspection is directly related to the amount of use the aircraft gets. The more you fly the more you need to inspect. The hotter or colder the conditions the more the stress on the airframe. Also dusty or wet conditions add to wear of parts and components.

Carbon fiber parts need to be inspected for cracks or stress, use a shop rag and wipe the surface of the carbon parts, if the rag gets hung up or caught on any carbon surface inspect the area, usually a piece of the rag will get caught on the small carbon fibers if they are damaged.

Nylon and plastic parts should be inspected for cracks, stripped out hardware, wear and or heat damage. Look for discoloration and warping as that is what plastic does when overheated. Nylon cannot be glued, it is advised to replace nylon parts if damaged. ABS can be field repaired using Acetone.

Hardware on the aircraft is a combination of metric 2.0mm 2.5mm 3.0mm and 4.0mm These fasteners often use blue loctite for security, loctite can adversely affect the durability of plastic. Be cautious when replacing hardware with loctite close to plastic parts, use loctite sparingly and be sure to remove excess. The aircraft also has many nuts installed, mostly 3mm nylock nuts, make sure at least a thread of the screw protrudes from the screw so the Nylon lock ring has contact with the screw. Other nuts may need loctite and or a lock washer if not using the self locking nylock nuts.

Aluminum parts inspect for dings, dents, bending, or cracks, corrosion. Repair or replace as required.

Landing gear are designed to keep the payload from touching the ground, they also function as a way to absorb a rough landing and are sacrificial. Make sure the gear locks into place when down and when retracted stays in place and is not loose, gear should remain in a position set by the handler and not swing freely, adjust as necessary.

Battery mounts are on condition inspected. The intent of the battery holder is similar to the landing gear, they are meant to break free in the event of a crash. Make sure the battery is firmly attached to the mount. Make sure the velcro strap is in good condition, if you see fraying, or the velcro doesn't hold as it should then replace the strap. Check for secure hardware and that the plastic is in good condition. Silicon tape is used as a surface for the battery to adhere to while attached. If the silicon tape is exposed to dust and debris it can reduce the stick the tape has and not keep the battery from sliding on the battery mount, please replace the silicone tape as needed to keep the battery from sliding while strapped to the mount.

Arms and Engine Mounts are on condition, if a hard landing or accident while ground handling has occurred please inspect the engine mount for proper orientation or damage. It is important the motor mount be parallel to the upper center plate of the airframe, the human eye can detect an engine mount that has rotated on the arm, simply loosen the engine mount screws a little, rotate the motor mount until the motor is level to the center plate and retighten the screws.

This airframe has foldable arms however this feature introduces areas of note to pay attention to if used frequently. The arms pivot at its root, this is done using screws, if the arms are folded it can loosen these screws, please keep a close eye on these screws as the arm can come loose over time. See diagram.

Payload Mount Rail: are a key function on mounting external payloads to the aircraft, it is a simple Picatinny rail that when coupled with the quick disconnect make it easy to attach and move payload articles. Make sure the rail is securely fastened and that the quick release is correctly attached. If you feel play in either the quick release of the mounting of the rail, inspect and adjust as necessary.

Engine and PowerTrain:

Motors: are on condition inspection, items to inspect are bearings for noise or friction. Play in the vertical axis of the motor, over time the collet at the bottom of the motor can come loose and cause the upper part of the motor to move away from the bottom part, if this occurs please resecure motor shaft collet per KDE manual. Get used to how it feels to move a motor by hand, we have multiple motors on the airframe and they all should behave the same way when manipulated. Bearings can wear out over time especially if in hot dusty climates, please routinely oil the bearings of the motor when needed.

ESC's: (electronic speed controller) drive the motors so they absorb the electrical loads of the engine and most likely suffer damage if the motor is suddenly stopped or prolong heavy loads are exerted. It is hard to inspect ESC's and usually it is recommended they are replaced if crashed. Contact ATI for more information.

<https://www.kdedirect.com/collections/uas-multi-rotor-brushless-motors/products/kde4012xf-400>

Propeller/Rotor: Propellers are carbon fiber and on condition inspected. If damage is suspect and a prop strike has occurred please inspect the propellers for cracks, out of balance or track, and mounting defects. Use a shop rag to wipe the whole surface of the propeller, if the rag catches on any carbon inspect further. Look for pieces of the shop rag on the propeller, if the carbon is compromised it will snare the rag. Make sure the propeller is tracking. Look for vibration coming from the engine by observing the aircraft in flight and looking at parts such as the landing gear leg for shaking or vibrating. Propeller mounts are aluminum, make sure the threads are in good condition and not showing signs of stripping. Some propeller mounts can bend if damaged so if you suspect a prop strike inspect the propeller mounts and hubs for damage. Cracks originating from center to 4 inches are considered unrepairable and unserviceable. The

only portion of the propeller that can be serviced is the tips. Contact ATI for service recommendation.

Some AgBots have three or two blade propellers that fold and need to be unscrewed to remove. If you have one of these propellers then you need to check blade tension on each blade relative to the blade holder before each flight. The blade holder is aluminum and it can change tension due to temperature and vibration. Ensure each propeller blade has the same tension, as a difference in tension can cause a blade to swivel more than the adjacent blade causing an out of phase (non equal degrees of separation, ie. 3 blade is 120deg, 2 blade is 180deg). Out of phase can cause vibration. The blade tension should be enough to eliminate play. When you unfold the blades they should stay in place and not loosely move on their own. It should require a small amount of effort to move or fold a blade.

If you see the end of your landing gear vibrate this can indicate a propeller that is out of balance, track or phase, OR something loose like an arm, engine mount etc... Please land and inspect propeller and airframe hardware and structure.

Power Distribution: The top plate of the aircraft is a PCB board designed to take battery power and distribute it to each arm and to the voltage regulation for the autopilot and accessory equipment installed on aircraft. DO NOT Drill holes in the top center plate of the aircraft as you could short out power and ground. Any cracks or bending of the top center plate deems it unsafe for operation and should be replaced.

Power Regulation: Each aircraft is equipped with 2 5VDC and 1 12VDC power regulators that get their power from the PBD. 1 5VDC is dedicated the power

Autopilot/Sensors: Autopilot is Pixhawk 1, Pixhawk 2.1, Cube Black or Cube Orange. Their hardware runs Ardupilot firmware. Inspect on condition mounting hardware and cables and connectors. Pixhawk 1 does not have locking connectors so ensure they are connected properly and secure. Ensure wire bend radius is not over 1.5 times the diameter of the wire gauge. Ensure servo connectors on the back of the autopilot are secure, they are not locking. Cube autopilots have locking connectors so make sure they are seated. Sometimes individual wires at the connector can become unseated, you will see the metal pin starting to protrude out the

back of the connector. If you see pins coming out of connectors contact ATI for repair procedures.

Antenna's depend on your specific radio controller, telemetry, and video link equipment integrated at the time of purchase. No matter what the configuration of your aircraft antennas must be installed correctly before power up. Most Radio Frequency gear and equipment cannot run correctly without the antenna installed and can cause substantial damage if operated without the antenna. Inspect antennas for damage and security, also inspect the antenna mounts for damage or security. Some antenna connections have different polarity connections. Pay close attention to the type of coax connection as it can be possible to put the wrong antenna on the wrong coax disconnect.

Payloads: There are many different types of payloads the aircraft can carry. From cameras to hooks, winches, or object releases, payloads have their specific requirements. However most payloads all require power to operate and therefore must be installed and removed from the aircraft without power applied. This is especially true for cameras. Make sure if you are going to install your payload that power is off when installed or removed. Make sure your payload is properly secured and connected. Make sure your payload is within the operating range of the airframe. It is possible to reduce battery weight if a heavier payload is required, just know that endurance and agility may be affected so fly the aircraft carefully when at maximum payload capacity is used. Contact ATI if you plan on altering the payload of the aircraft dramatically.

Appendix C:

Components and Limits

Purpose: Below is a list of components and limitations for the VR Drone Hexacopter. These limits are based on conditions of ambient temperature, pressure, at sea level. Conditions directly impact aircraft performance so take into consideration the current environment and adapt. If this is a new location, and the current conditions are new, please take the time to consult manuals, documentation, and the manufacturer for guidance.

- Airframe Configuration: VTOL Hexacopter, Material Carbon Fiber Frame, Nylon, ABS, Aluminum
- Motor: DJI 4014 400Kv, ESC DJI 40 Amp, Max Power 500W
- Propeller: DJI split prop 15"x5.2
- Flight Controller: Ardupilot, Cube Black, Here GPS
- Ground Control: PC, Android, iOS.
- Flight Radio: Taranis X9D, Radiomaster, HereLink
- Datalink: TBS 900mhz, RFD900x
- Operating Temperature: -10 to +40 Deg C
- Operating Freq: 5.8 GHz, 2.4 GHz, 900 Mhz
- Operating Freq Range: 1 mile to 26 mile Depending on configuration.
- Weight (incl. gimbal and battery) 4.7 kg (10.4 lbs)
- Basic Empty Weight: 5.7 KG

- Max TO weight: 8.2 KG
- Length (Motor Center to Center) 81.1cm (32 in) Height 53.1cm (20.1 in)
- Case Dimension 112 x 40.9 x 35.5 cm (44.16 x 16.09 x 14 in) Loaded Case Weight 24.3 kg (53.6 lbs)
- System Power 25 Volt, Battery Dual 6S 7000 mAh, 25C, Quad Battery 6S 4500 25C, Available 5VDC regulated and 12VDC Regulated less than 10 Amp.
- Charger 12-24 Volt 500W 2 Channel Multi Charger: Power supply 115, 240 VAC input 12VDC 40 Amp Output
- Flight Time (no payload) 15 Min with reserve.

Appendix D:

Wiring Diagrams and Schematics

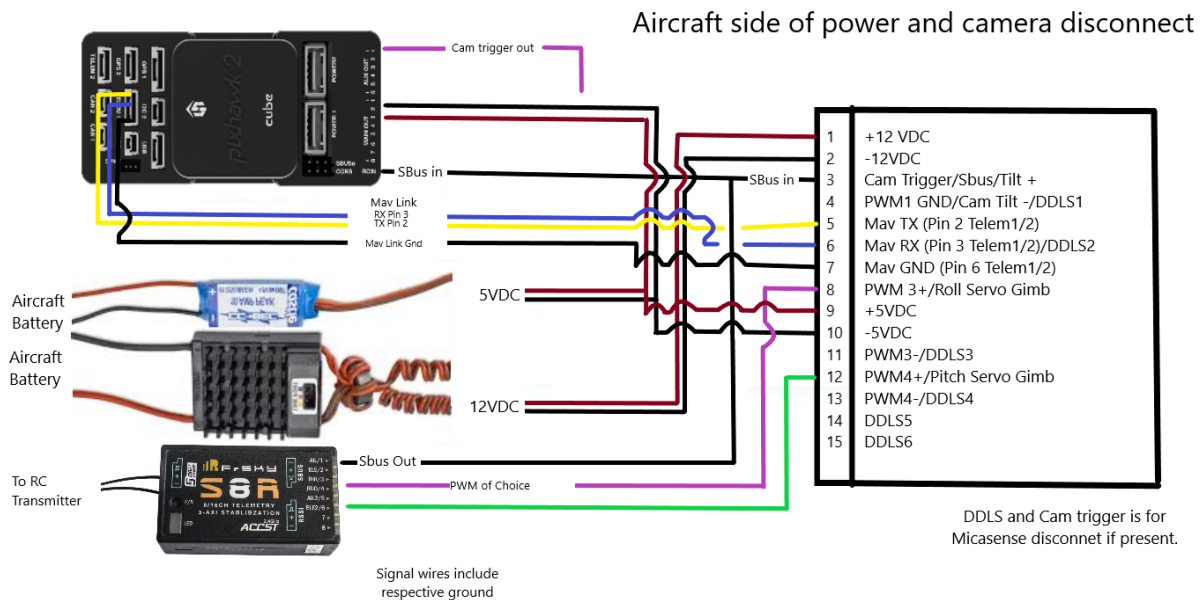

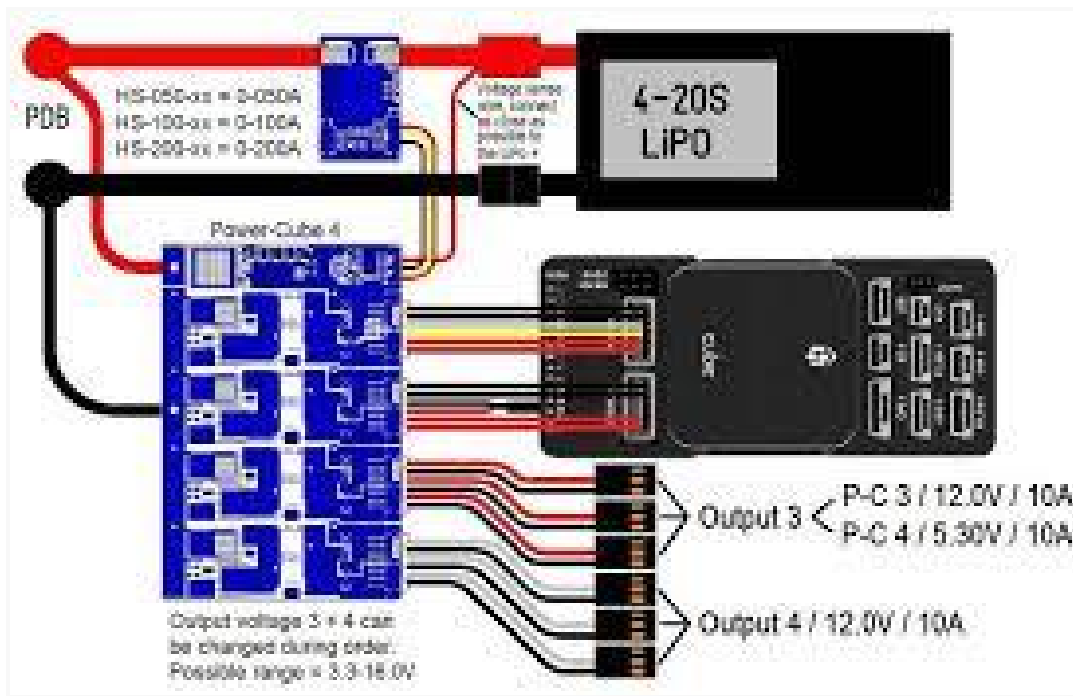

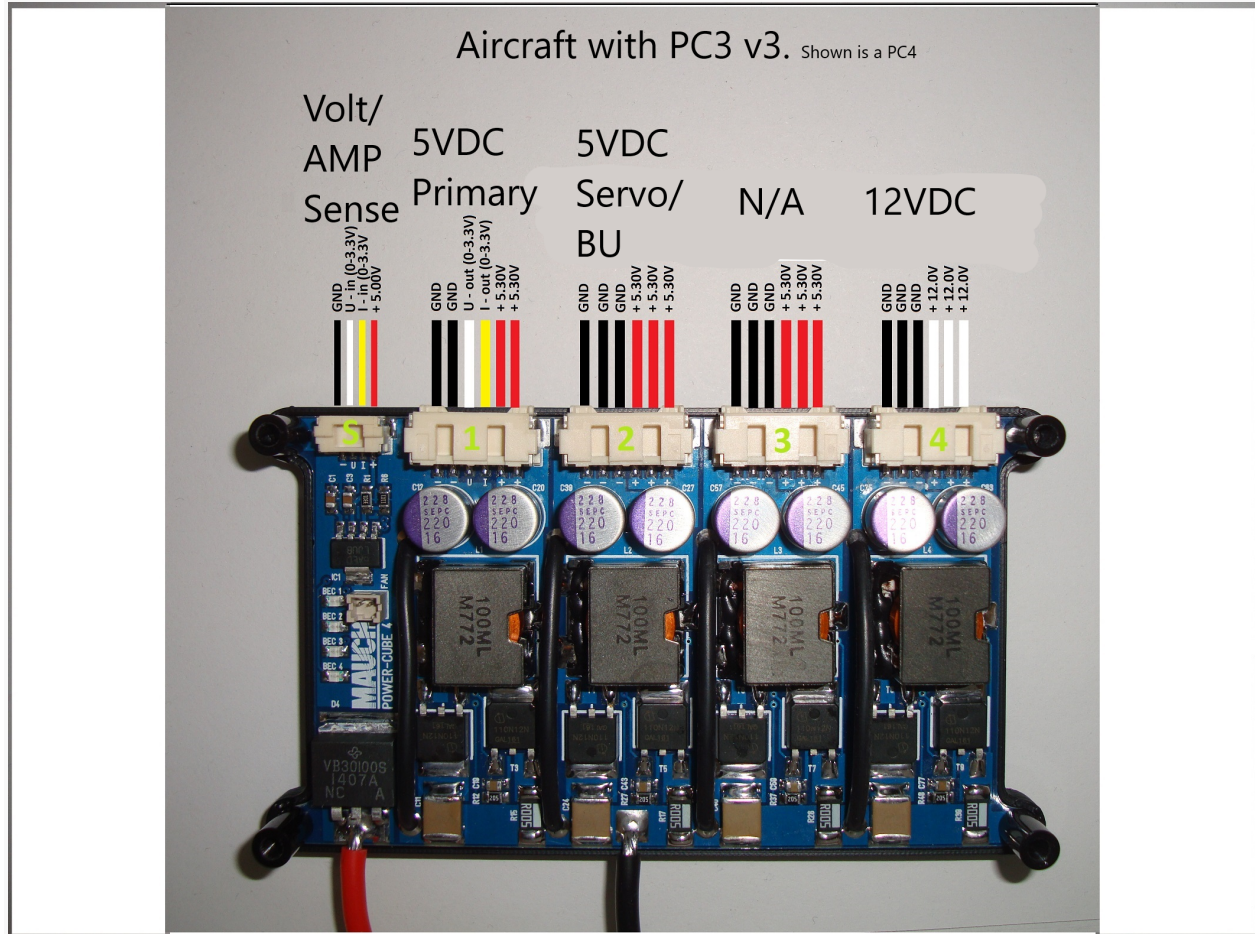

BOT AIRCRAFT CONTROLLER LAYOUT



SA= RTL (Return to Launch)	SE= N/A, Cam Mode, Pan, Stow
SB= Cam Trigger/Start Stop Rec	SF= Lights
SC= N/A, IOC, Alternate Mode	SG= N/A, Cam Zoom
SD= MODE Loiter	SH= N/A
ALT Hold	RS= N/A
Auto	S1= N/A, Cam Pan
LS= Cam Tilt	S2= N/A
Long Push Page Button= Telem	Exit=Home screen

